

C56

HALF PITCH BOX HEADER STRAIGHT SMT TYPE WITH UNDERCUT

PITCH: 1.27mm

SPECIFICATIONS

Material

Insulator : LCP, glass reinforced, rated UL 94V-0

Contact : Phosphor Bronze

Electrical

Current Rating : 1 Amp

Contact Resistance : 30 mΩ max.

Insulation Resistance : 1000 MΩ min.

Dielectric Withstanding Voltage :250V AC for 1minute

Operating Temperature : -40°C to +105°C

◆ Mating Suggestion : A32b series.

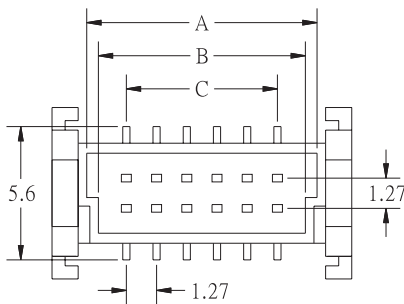
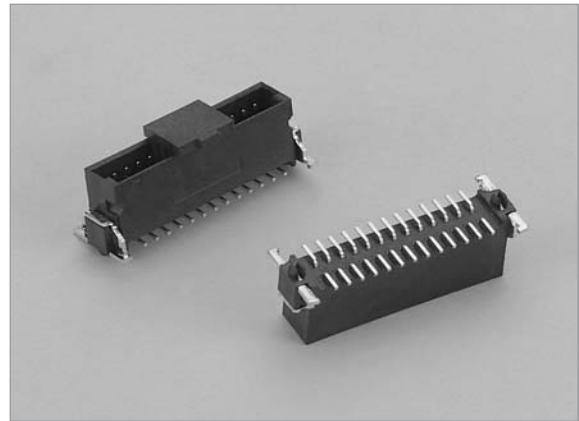

POSITION	A	B	C	D	E	F
12	9.68	8.70	6.35	12.60	10.40	10.77
26	18.57	17.59	15.24	21.60	19.29	19.66
50	33.81	32.83	30.48	36.80	34.53	34.90
68	45.24	44.26	41.91	48.20	45.96	46.33
80	52.86	51.88	49.53	55.80	53.58	49.53

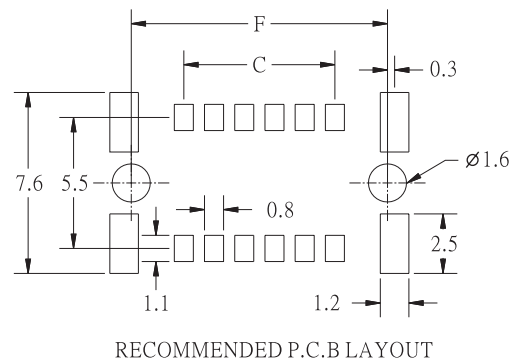
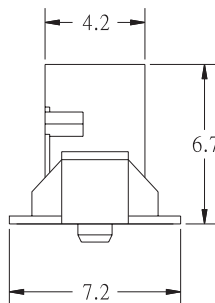
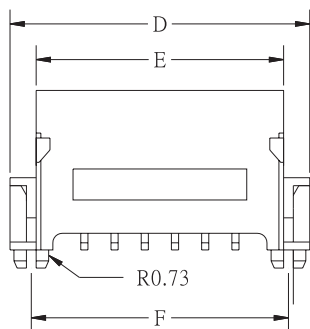

HOW TO ORDER:

C56 - - - -

1.NO. OF CONTACT	2.CONTACT MATERIAL	3.CONTACT PLATING	4.INSULATOR COLOR
12 26 50 68 80	B: PHOSPHOR BRONZE	T: TIN PLATED S: SELECTIVE G: GOLD FLASH A: 5u" INCH GOLD B: 10u" INCH GOLD C: 15u" INCH GOLD D: 30u" INCH GOLD	1. BLACK

C